

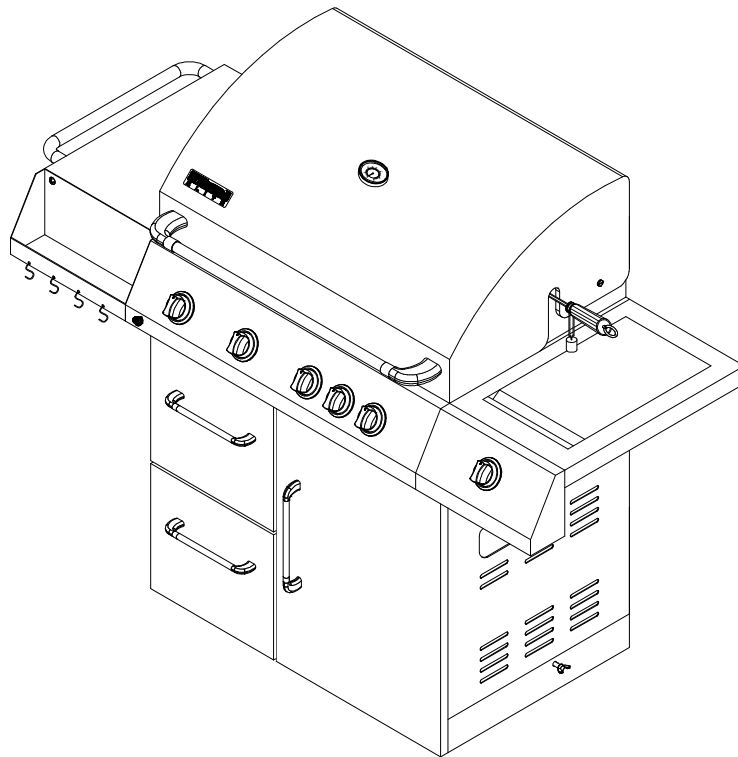

Owner's Manual

Liquid Propane Gas Grill

Sears Model No.:650-30643-0



WARNING:

Read this Owner's manual carefully and be sure your gas grill is properly assembled, installed and maintained. Failure to follow these instructions could result in serious injury and/or property damage. This gas grill is intended for outdoor use only and is not intended to be installed in or on recreational vehicles or boats.

Note to Installer

Leave this Owner's Manual with the customer after delivery and/or installation.

Note to Consumer

Leave this Owner's Manual in a convenient place for future reference and keep receipt as proof of purchase to validate the warranty.

Customer Service Helpline:

For questions and warranty parts, call helpline 8 AM to 5 PM EST at:
1-800-469-4663

Date: 2006/02/22

Table of Contents

Warranty-----1
 Safety Precautions-----1~2
 Pre-assembly Instructions-----3
 Hardware List-----4
 Parts Diagram -----5
 Parts List-----6
 Assembly Instructions-----7~10
 Lighting Instructions-----11~12
 Cleaning and Maintenance-----13~14
 Trouble Shooting-----15
 Getting Started With Your Grill-----16
 Rotisserie Kit Assembly/Use instruction-----17
 Cooking Chart-----18~20
 Recipes Suggestions-----21~23

Kenmore Elite Warranty

Limited Warranty on Grill Parts

Sears will replace the following grill parts at no charge if they are defective in material or workmanship and if the parts are still under warranty. You will be charged for labour.

Component	Warranty Period
Burners:	5 Years
Flame Tamers:	3 Years
Cast Iron Cooking Grids:	3 Years
Valves:	1 Year
Frame, Housing, Cart, Control Panel, Igniter, and Related Parts to Above:	1 Year
All Stainless Steel Parts:	3 Years
All other parts	1 Year

Warranty Service

- Warranty service is available by contacting your nearest Sears Service Center.

Warranty Restrictions

- This warranty is void if grill is to be used for commercial or rental purposes.
- This grill is for use with Liquid Propane (LP) gas only. Any attempt to convert this grill to natural gas is dangerous and will void your product warranty.
- This warranty applies only when the grill is used in Canada.
- This warranty gives you specific legal rights, and you may also have other rights which vary from province to province.

**Sears Canada Inc.,
 Toronto, Ontario
 M5B 2B8**

PRECAUTIONS

 **WARNING**
 Combustion by products produced when using this product contain chemicals known to the State of California to cause cancer, birth defects, or other reproductive harm.

 **WARNING**
 Failure to comply with these instructions could result in a fire or explosion that could cause serious bodily injury, death, or property damage.

 **WARNING**
Your grill will get very hot. Never lean over the cooking area while using your grill. Do not touch cooking surfaces, grill housing, lid or any other grill parts while the grill is in operation, or until the gas grill has cooled down after use.
Failure to comply with these instructions may result in serious bodily injury.

-  **WARNING**
- Do not store or use gasoline or other flammable material and liquids in the vicinity of this or any other appliance.
 - A LP cylinder not connected for use must not be stored in the vicinity of this or any other appliance.

-  **DANGER**
- If you smell gas:
- Shut off gas to the appliance.
 - Extinguish any open flame.
 - Open Lid.
 - If odour continues, keep away from the appliance and immediately call your gas supplier or your fire department .

Grill Installation Codes
 A statement that the installation must conform with local codes or, in the absence of local codes, with either the national fuel gas code, ANSI Z223.1/NFPA 54, Natural gas and propane installation code, CSA B149.1, or propane storage and handling code, B149.2, or the standard for Recreational vehicles, ANSI A 119.2, and CSA Z240 RV series Recreational vehicle code, as applicable.
Correct LP Gas Tank Use
 LP gas grill models are designed for use with a standard 20 lb. Liquid Propane Gas tank, not included with grill. **Never** connect your gas grill to an LP gas tank that exceeds this capacity.

PRECAUTIONS

A tank of approximately 12 inches in diameter by 18-1/2 inches high is the maximum size LP gas tank to use. **You must use an OPD gas tank which offers an Overfill Prevention Device.**

This safety feature prevents the tank from being overfilled which can cause malfunction of the LP gas tank, regulator and/or grill.

The LP gas tank must be constructed and marked in accordance with specifications of the U.S. Dept. of Transportation (DOT). In Canada, the LP gas tank must meet the National Standard of Canada, Can CSA –B339, Cylinders, spheres and Tubes for Transportation of Dangerous Goods and Commission.

1. The LP gas tank must have a shutoff valve, terminating in an LP gas supply tank valve outlet, that is compatible with a Type 1 tank connection device. The LP gas tank must also have a safety relief device that has a direct connection with the vapor space of the tank.
2. The tank supply system must be arranged for vapor withdraw.
3. The LP gas tank used must have a collar to protect the tank valve.

Proper Placement and Clearance of Grill

Never use your gas grill in a garage, porch, shed, breezeway or any other enclosed area. Your gas grill is to be used **outdoors only**, at least 24 inches from the back and side of any combustible surface. Your gas grill should not be used under overhead combustible construction. Do not obstruct the flow of ventilation air around the gas grill housing.

This outdoor gas grill is not intended to be installed in or on recreational vehicles and/or boats.

- **Never** connect an unregulated LP gas tank to your gas grill. The gas regulator assembly supplied with your gas grill is adjusted to have an outlet pressure of 11" water column (W.C.) for connection to an LP gas tank.
- Only use the regulator and the hose assembly supplied with your gas grill. Replacement regulators and hose assemblies must be those specified in this manual.
- Have your LP gas tank filled by a reputable propane gas dealer and visually inspected and re-qualified at each filling.
- a) Do not store a spare LP gas cylinder under or near this appliance.
- b) Never fill the cylinder beyond 80 percent full.
- c) If the information in a) and b) is not followed exactly a fire causing death or serious injury may occur.
- Always keep LP gas tanks in an upright position.
- Do not store (or) use gasoline or other flammable vapors and liquids in the vicinity of this gas grill.
- Do not subject the LP gas tank to excessive heat.

- Never store an LP gas tank indoors. If you store your gas grill in the garage or other indoor location, **always** disconnect the LP gas tank first and store it safely outside.



- Place dust cap on cylinder valve outlet whenever the cylinder is not in use. Only install the type of dust cap on the cylinder valve outlet that is provided with the cylinder valve. Other types of caps or plugs may result in leakage of propane.
- LP gas tanks must be stored outdoors in a well-ventilated area and out of reach of children. Disconnected LP gas tanks must not be stored in a building, garage or any other enclosed area.
- When your gas grill is not in use the gas must be turned off at the LP gas tank.
- The regulator and hose assembly must be inspected before each use of the grill. If there is excessive abrasion or wear or if the hose is cut, it must be replaced prior to the grill being used again.
- Keep the gas regulator hose away from hot grill surfaces and dripping grease. Avoid unnecessary twisting of hose. Visually inspect the hose prior to each use for cuts, cracks, excessive wear or other damage. If the hose appears damaged do not use the gas grill. Call 1-800-361-6665 for a Sears authorized replacement hose.
- **Never** light your gas grill with the lid closed or before checking to ensure the burner tubes are fully seated over the gas valve orifices.
- **Never** allow children to operate your grill.



WARNING

A strong gas smell, or the hissing sound of gas indicates a serious problem with your gas grill or the LP gas tank. Failure to immediately follow the steps listed below could result in a fire or explosion that could cause serious bodily injury, death, or property damage.

- Shut off gas supply to the gas grill.
- Turn the control knobs to OFF position.
- Put out any flame with a proper fire extinguisher.
- Open Grill Lid.
- Get away from the LP gas tank.
- Do not try to fix the problem yourself.
- If odour continues or you have a fire you can not extinguish, call your fire department. Do not call from near the LP gas tank because your telephone is a form of electrical device and could create a spark resulting in fire and/or explosion.

NOTE: The normal flow of gas through the regulator and hose assembly can create a humming noise. A low volume of noise is perfectly normal and will not interfere with operation of the grill. If humming noise is loud and excessive you may need to purge air from the gas line or reset the regulator excess gas flow device. This purging procedure should be done every time a new LP gas tank is connected to your grill. For help with this procedure refer to page 13, step 4, or call the Customer Service Helpline 8 AM to 5 PM EST at: 1-800-469-4663

CAUTION: Beware of Flash-back

CAUTION: Spiders and small insects occasionally spin webs or make nests in the grill burner tubes during transit and warehousing. These webs can lead to gas flow obstruction which could result in a fire in and around burner tubes. This type of fire is known as “FLASH-BACK” and can cause serious damage to your grill and create an unsafe operating condition for the user.

Although an obstructed burner tube is not the only cause of “FLASH-BACK”, it is the most common cause.

To reduce the chance of “FLASH-BACK”, you must clean the burner tubes before assembling your grill, and at least once a month in late summer or early fall when spiders are most active. Also perform this burner tube cleaning procedure if your grill has not been used for an extended period of time.

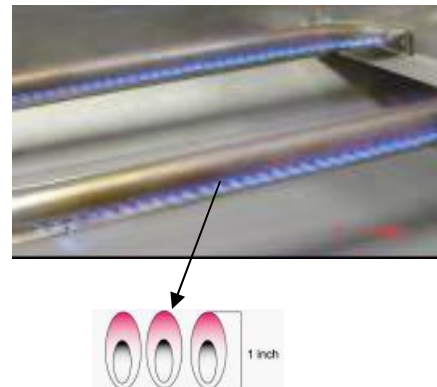

Visually check the burner flames prior to each use. The flames should look like this picture, if they do not, refer to the burner maintenance part of this manual.

Contents for Hardware Pack (part #643-072)

The following table illustrates a breakdown of the hardware pack. It highlights what components are used in the various stages of assembly.

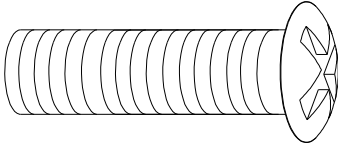
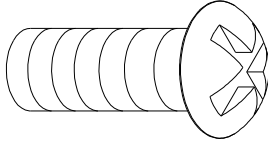
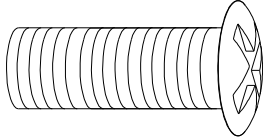
1/4" x 15mm Philips Head Screw	
1/4" x 10mm Philips Head Screw	
5/32" x 10mm Philips Head Screw	

Component	Q'ty	Purpose of Components
1/4" x 10mm Philips Head Screw	3	Attach Condiment Holder to Left Side Shelf
1/4" x 10mm Philips Head Screw	3	Attach Side Control Panel to Side Burner Shelf
1/4" x 15mm Philips Head Screw	2	Attach Left Side Shelf to Fire Box
1/4" x 10mm Philips Head Screw	2	
1/4" x 15mm Philips Head Screw	2	Attach Right Side Burner to Fire Box
1/4" x 10mm Philips Head Screw	2	
5/32" x 10mm Philips Head Screw	1	Attach Condiment Holder to Main Control Panel
5/32" x 10mm Philips Head Screw	1	Attach Side Control Panel to Main Control Panel
5/32" x 10mm Philips Head Screw	2	Attach Side Valve to Side Control Panel
1/4" x 10mm Philips Head Screw	2	Attach Side Handle to Left Side Shelf
AA Battery	1	Powers the Electric Ignitor
Allen Wrench	1	Secures Knobs to Valve Heads

Sears Model 30643 Parts Diagram (Manufacturer model #: 720-0286)

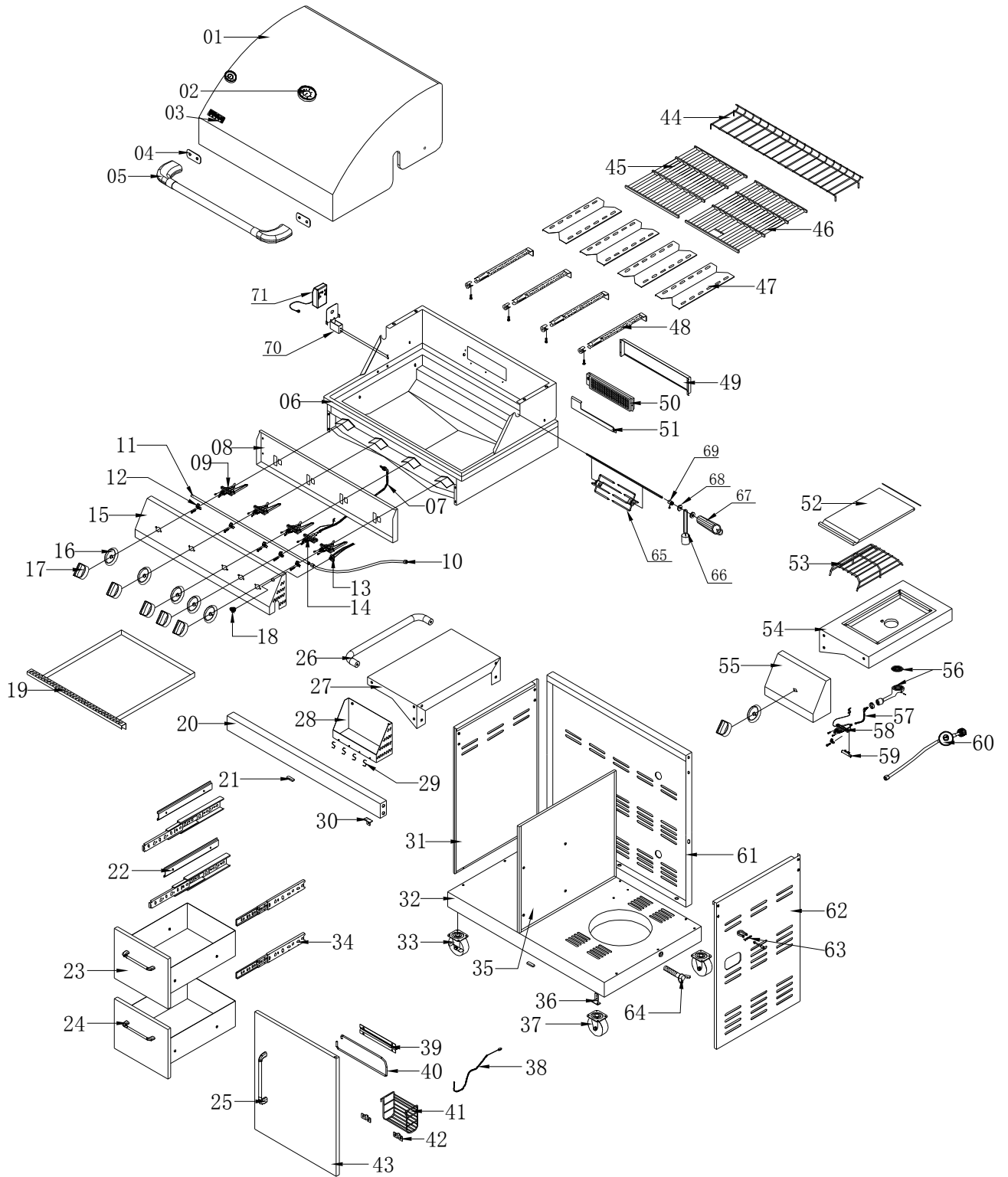

Sears Model 30643 Parts List (Manufacturer model #: 720-0286)

KEY #	PART #	DESCRIPTION	QTY
01	653-001	Stainless Steel Main Lid	1
02	653-002	Temperature Gauge	1
03	653-003	Name Plate	1
04	653-004	Heat Gasket	2
05	653-005	Main Lid Handle	1
06	653-006	Bowl Assembly	1
07	653-007	Flex Pipe for Rear Burner	1
08	653-008	Front Baffle	1
09	653-009	Main Valve	4
10	653-010	Side Burner Hose	1
11	653-011	Manifold	1
12	653-012	Valve clip	5
13	653-013	Ignitor Wire	1
14	653-014	Rear Burner Valve	1
15	653-015	Main Control Panel	1
16	653-016	Knob Bezel	6
17	653-017	Knob	6
18	653-018	Ignitor Button	1
19	653-019	Grease Tray	1
20	653-020	Door Support Beam	1
21	653-021	Door Magnet	1
22	653-022	Drawer Slider	4
23	653-023	Drawer	2
24	653-024	Drawer Handle	2
25	653-025	Door Handle	1
26	653-026	Side Push Bar	1
27	653-027	Left Side Shelf	1
28	653-028	Condiment Tray	1
29	653-029	S Hook	4
30	653-030	Top Door Hinge Bracket	1
31	653-031	Left Side Panel	1
32	653-032	Bottom Panel	1
33	653-033	Caster with Brake	2
34	653-034	Drawer Glide	4
35	653-035	Center Cart Panel	1
36	653-036	Bottom Door Hinge Bracket	1
37	653-037	Caster without Brake	2

KEY #	PART #	DESCRIPTION	QTY
38	653-038	Lighting Rod	1
39	653-039	Towel Holder Bracket	1
40	653-040	Towel Holder Hook	1
41	653-041	Condiment Rack	1
42	653-042	Condiment Rack bracket	2
43	653-043	Door	1
44	643-044	Warming Rack	1
45	643-045	Left Cooking Grid	1
46	643-046	Right Cooking Grid	1
47	643-047	Flame Tamer	4
48	643-048	Stainless Steel Burner	4
49	643-049	Rear Casing for Rear Burner	1
50	643-050	Rear Burner	1
51	643-051	Gas Collector	1
52	643-052	Side Burner Lid	1
53	643-053	Side Burner Cooking Grid	1
54	643-054	Side Burner Shelf	1
55	643-055	Side Control Panel	1
56	643-056	Side Burner	1
57	643-057	Gas Line	1
58	643-058	Side Burner Valve	1
59	643-059	Side Manifold	1
60	643-060	Regulator and hose	1
61	643-061	Back Panel	1
62	643-062	Right Side Panel	1
63	643-063	LP hose retention kit	1
64	643-064	Tank Retention Bolt	1
65	643-065	Spit Fork	2
66	643-066	Counter Balance	1
67	643-067	Rotisserie Handle	1
68	643-068	Key Washer	2
69	643-069	Shaft Collar	1
70	643-070	Motor Bracket	1
71	643-071	Rotisserie Motor	1
72	643-072	Owner's Manual	1
73	643-073	Hardware Pack	1

If you have question about assembly, call the Customer Service Helpline 8am – 5pm EST, Monday through Friday at: **1-800-469-4663**
For repair and replacement parts you need: 24 hours a day, 7 days a week at:

1-800-4-MY-HOME (1-800-469-4663)

To make sure you obtain the correct replacement parts for your Kenmore gas grill, please refer to the part numbers on this page. The following information is required to assure you receive the correct parts:

1. Part Number (see REF# in chart)
 2. Part Description
 3. Quantity of parts needed
- Example: 643-001 stainless steel main lid – 1 pc

Important: Keep this Owner's Manual for convenient reference and for part replacement.

Important: Use only Sears authorized parts. The use of any part that is not Sears authorized can be dangerous and will also void your product warranty.

Assembly Instructions

Caution: While it is possible for one person to assemble this grill, obtain assistance from another person when handling some of the larger, heavier pieces.

1. Open lid of shipping carton and remove top sheet of cardboard. Lay cardboard sheet on floor and use as a work surface to protect floor and grill parts from scratches.
2. Remove packing materials from shipping carton.
3. You may slice the carton front corners with a utility knife to lay open the carton front panel. This will allow you to raise the grill head lid and remove the components packed inside the head.
4. Use the parts list to check that all parts have been included.
5. Inspect the grill for damage as you assemble it. Do not assemble or operate the grill if it appears damaged. If there are damaged or missing parts when you unpack the shipping box, or you have questions during the assembly process, call:

1-800-469-4663

8am – 5pm EST, Monday through Friday.

Installing Side Shelves

1. Attach side condiment holder to left side shelf by using $\frac{1}{4}$ " x 15mm Philips head screws. (Fig.1)
2. Attach side control panel to side burner shelf by using $\frac{1}{4}$ " x 15mm Philips head screws. (Fig.2)
3. Attach side shelves to both sides of grill by using $\frac{1}{4}$ " x 15mm Philips head screws. (Fig.3)
4. Secure condiment holder to the left of main control panel by using $\frac{1}{4}$ " x 10mm Philips head screw. Secure side control panel to the right of main control panel by using $\frac{1}{4}$ " x 10mm Philips head screw. (Fig.4)

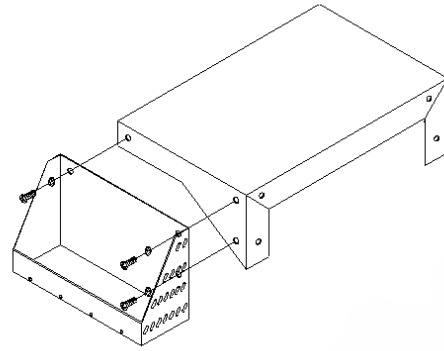

Figure 1

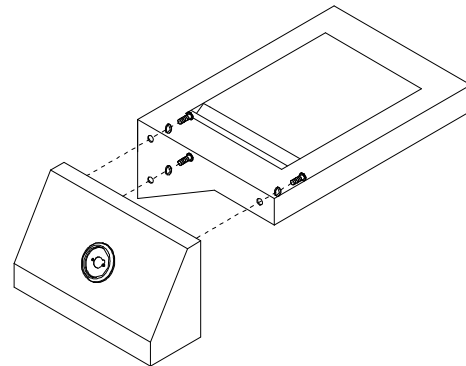

Figure 2

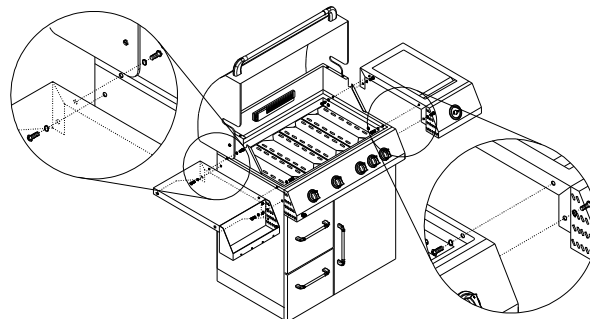

Figure 3

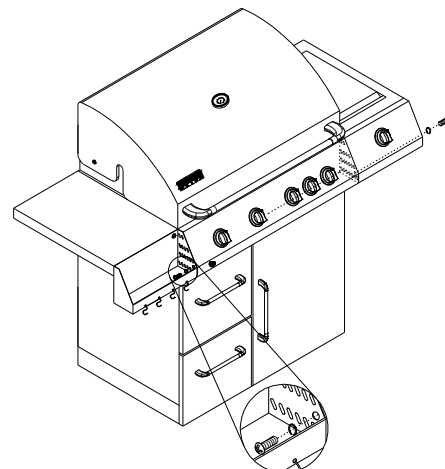

Figure 4

Installing Side Burner

1. Insert valve assembly through side panel right (Fig. 5-a). Remove 4(four) screws & washers from the "U" brackets on the side burner. (Fig. 5-b). Insert valve stem assembly into burner tube (FIG 5-c).
2. Secure side valve to side control panel by using philips head screws through the round cover plate (know bezel). (Fig.6)
3. Replace "U" brackets with four screw(DO NOT TIGHTEN, MAKE SURE HOSE IS NOT BENT). (Fig.7). Then align & tighten knob seat & valve stem with 2 screws & washers
4. Tighten all four screws on the "U" bracket on the burner, then connect ignitor wire to ignitor. (Fig.8)
5. Secure knob to head of side valve with the provided Allen Wrench. (Fig.9)

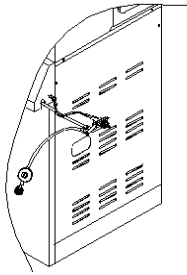

Figure 5-a

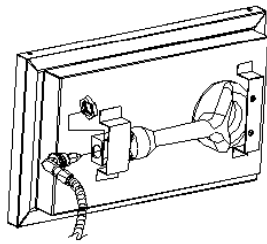

Figure 5-b

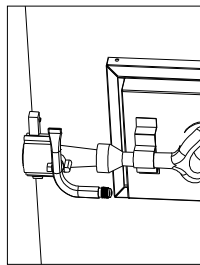

Figure 5-c

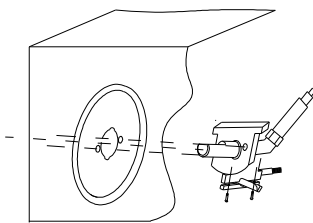

Figure 6

Installing S Hook

Align 4 S hooks into 4 holes in condiment holder, and close (Fig.10)

Installing Side Handle

Secure side handle to left side shelf by using 5/32" x 10mm Philips head screws. (Fig.11)

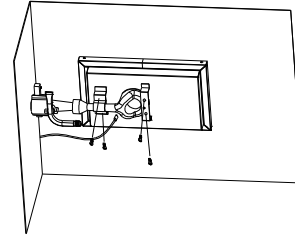

Figure 7

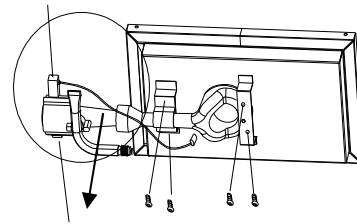

Figure 8

Ignition wire

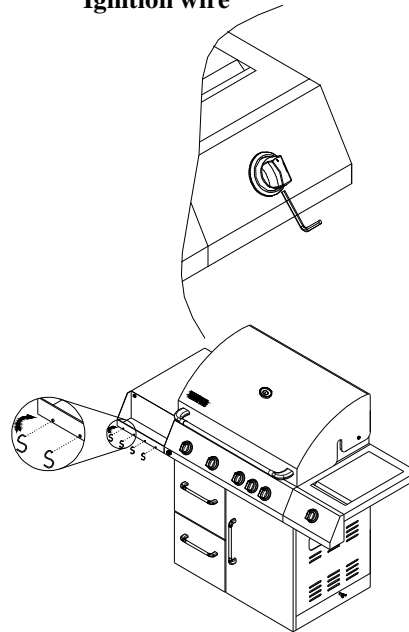

Figure 9

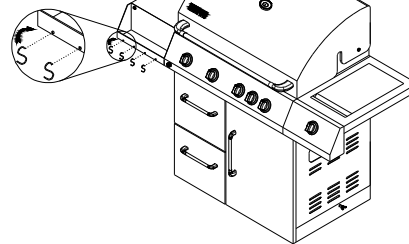

Figure 10

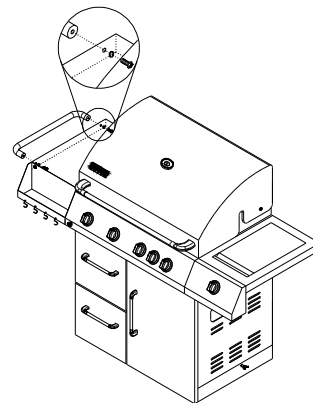

Figure 11

Installing Condiment Rack

Attach condiment rack to inside door panel. (Fig.12)

Installing Cooking Components

Important: Before cooking on your grill the first time, wash cooking grids and cooking rack with warm , soapy water. Rinse and dry thoroughly. Season with cooking oil regularly. After cooking is completed, turn grill for HIGH setting 3 to 5 minutes to burn off excess grease or food residue.

1. Evenly space cooking grids on the ledge above flame tamers. (Fig.13)
2. Place warming rack into the holes of the upper left and upper right of grill bowl side panels. (Fig.13)

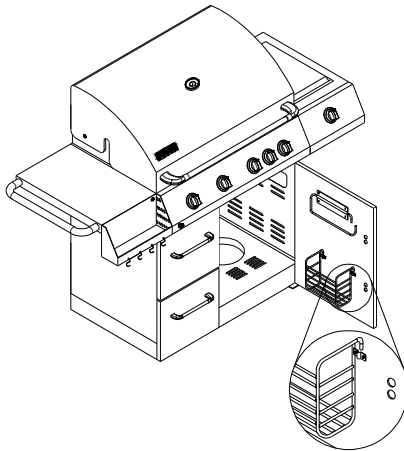

Figure 12

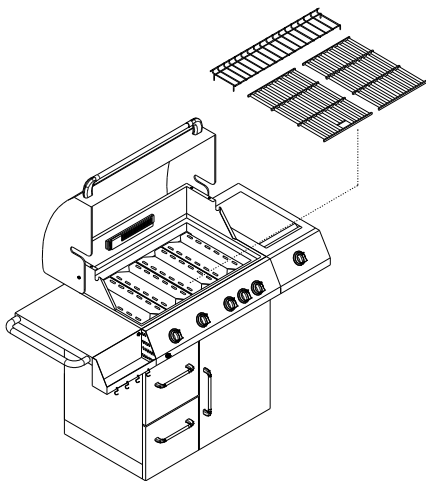

Figure 13

Assembly Tips

Ignitor Battery Installation

1. Unscrew the ignitor cap located on control panel and remove the contact and spring from the ignitor slot.
2. Place the manufacturer supplied AA battery into the ignitor slot. Be sure to place the positive pole facing toward you. (Fig. 14)
3. Place the spring over the AA battery, then place the contact on top of the spring. Screw the ignitor cap back onto control panel.

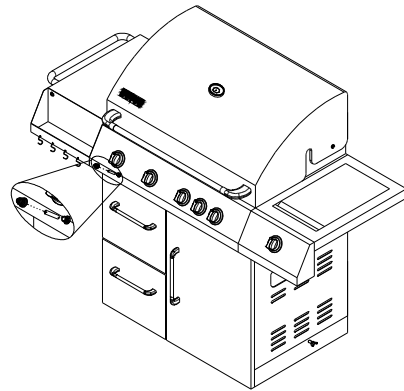

Figure 14

Installing Gas hose Retention Kit

- 1a. Insert “threaded end” mounting bolt through top middle vent on the bottom right panel. (Fig 15-a)
- 1b. Tighten nut with washer from the out side of panel with the provided wrench (Fig 15-b)
- 2a. Put regulator hose through ring clamp (Fig 15-c)
- 2b. Use wing bolt to fasten regulator hose to ring clamp securely. (Fig 15-d)



Figure 15-a



Figure 15-b



Figure 15-c

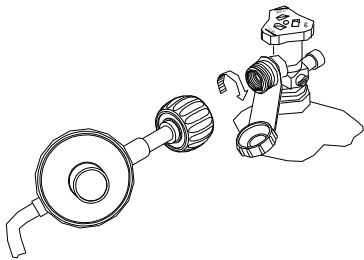

Figure 15-d

- Ignitor AA battery not installed properly.
- Ignitor wires may be loose. Remove AA battery, inspect the ignitor junction box found behind control panel, and connect any loose wires.

Connecting LP gas tank to LP grill

1. Open the front doors of cabinet. Place the 20 lb tank with foot ring into the hole in bottom shelf. Make sure the tank valve is in OFF position. (Fig. 16)
2. Check the tank valve to ensure it has proper external mating threads to fit the hose & regulator assembly provided.
3. Make sure all burner valves are in OFF position.
4. Inspect the valve connection port and regulator assembly. Look for damage or debris. Remove any debris. Inspect hose for damage. Never use damaged or plugged equipment.
5. Place regulator and hose assembly through gap between right cart leg and grill head. When connecting regulator and hose assembly to tank valve hand tighten quick coupling nut clockwise to a full stop. Do not use a wrench to tighten because it could damage the quick coupling nut and result in a hazardous condition.
6. Open tank valve fully (counterclockwise). Use a soapy water solution to check all connections for leaks before attempting to light your grill. If a leak is found, turn tank valve off and do not use your grill until the leak is repaired.



CAUTION: When the appliance is not in use, gas must be turned off at the supply tank.

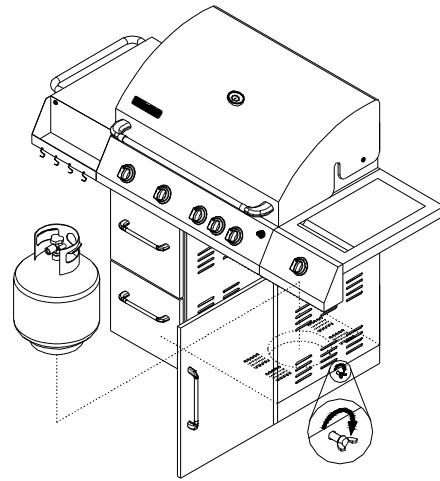

Figure 16

Congratulations

Your Kenmore gas grill is now ready for use. Before the first use and at the beginning of each season (and whenever the LP gas tank has been changed):

1. Read all safety, lighting and operating instructions.
2. Check gas valve orifices, burner tubes and burner ports for any obstructions.
3. Perform gas leak check according to instructions found on this page of the manual.

Checking for LP gas leaks

Never test for leaks with a flame. Prior to first use, at the beginning of each season, or every time your LP gas tank is changed, you must check for gas leaks. Follow these 4 steps:

1. Make a soap solution by mixing one part liquid detergent and one part water.

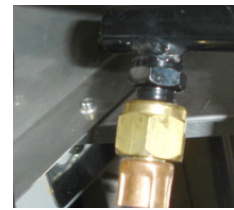

2. Turn control knobs to full OFF position, then turn gas ON at source.
3. Apply the soap solution to all gas connections. If bubbles appear in the solution the connections are not properly sealed. Check each fitting and tighten or repair as necessary.
4. If you have a gas leak you cannot repair, turn off gas at the source, disconnect fuel line from your grill and call 1-800-4-MY-HOME or your gas supplier for repair assistance.

Grill Lighting Instruction

Basic Lighting Procedures

1. Familiarize yourself with the safety guidelines at the front of this manual. Do not smoke while lighting grill or checking gas supply connections.
2. Be sure the LP gas tank is filled.
3. Check that the end of each burner tube is properly located over each valve orifice.
4. Be sure all gas connections are securely tightened.

Main Burner Lighting Instruction

1. Make sure the Lid is open

⚠ WARNING

Failure to open grill lid during the lighting procedure could result in a fire or explosion that could cause serious bodily injury, death, or property damage.

2. Push and turn one of main or side burner knobs to HI/Ignite position



3. You may need to try 3 or 4 times to light the burner. After the burner is lit, adjust the knob as desired.

Rear Burner Lighting Instruction

- Step 1. Push and turn the desired knob to HI/Ignite



- Step 2. Press the electric igniter 3 to 4 seconds to light the rotisserie burner



- Step 3. After the rotisserie burner is lit, adjust the knob as desired

Manually Lighting Your Grill by Match

1. Open the doors and take out the manual lighting stick from back of right door. (Fig.16)
2. Insert a match into the lighting stick.
3. Follow steps 1 through 6 of the Basic Lighting Procedure.
4. Light the match and extend the lighting stick to cooking grid surface.
5. Turn the desired control knob to the HIGH/Ignite setting to release gas. The burner should light immediately.
6. To light side and rear burners, repeat step one to five

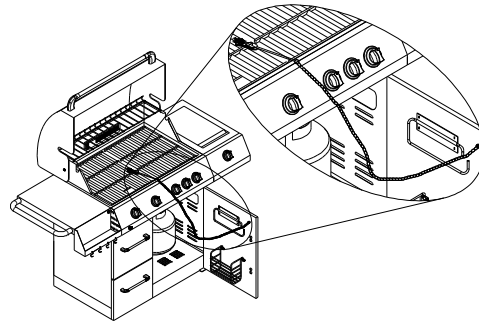
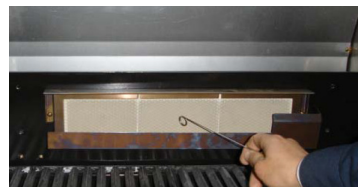

Figure 16



⚠ WARNING

Never lean over the grill cooking area while lighting your gas grill. Keep your face and body a safe distance (at least 18 inches) from the cooking grid surface when lighting your grill by match.

If the grill fails to light:

1. Turn gas off at source and turn the control knob to OFF, wait at least 5 minutes for gas to clear, then try again.

2. If your grill still fails to light, check gas supply and connections.

3. Repeat lighting procedure. If your grill still fails to operate, turn the gas off at source, turn the control knobs to OFF, then check the following:

- Misalignment of burner tubes over orifices

Correction: Reposition burner tubes over orifices.

- Obstruction in gas line

Correction: Remove fuel line from grill. Do not smoke! Open gas supply for 1 second to clear any obstruction from fuel line. Close off gas supply at source and reconnect fuel line to grill

- Plugged orifices

Correction: Remove burners from grill, carefully lift each burner up and away from gas valve orifices. Remove the orifices from gas valve and gently clear any obstruction with a fine wire. Then reinstall all orifices, burners, and cooking components.

If an obstruction is suspected in gas valves, please call for repair service at 1-800-4-MY-HOME

If the grill still does not light you may need to purge air from the gas line or reset the regulator excess gas flow device. **Note:** This procedure should be done every time a new LP gas tank is connected to your grill.

To purge air from your gas line and/or reset the regulator excess gas flow device:

- Turn the control knob to OFF position.
- Turn off the gas at the tank valve.
- Disconnect regulator from LP gas tank.
- Let unit stand for 5 minutes.
- Reconnect regulator to the LP gas tank.
- Turn the tank valve on slowly until $\frac{1}{4}$ to $\frac{1}{2}$ open.
- Open the grill lid.
- Set control knobs to OFF. Push and turn the left control knob to HIGH.

5. If all checks or corrections have been made and you still have questions about operating your gas grill, call the **Customer Service Helpline 8am – 5pm EST, Monday through Friday at 1-800-469-4663**

**WARNING**

Should a “FLASH-BACK” fire occur in/or around the burner tubes, follow the instructions below. Failure to comply with these instructions could result in a fire or explosion that could cause serious bodily injury, death, or property damage.

- Shut off gas supply to the gas grill.
- Turn the control knobs to OFF position.
- Put out any flame with a proper fire extinguisher.
- Open grill lid.
- Once the grill has cooled down, clean the burner tubes and burners according to the cleaning instructions found on page 13~14.

Cleaning and Maintenance

To ensure a proper working unit the following proper care and maintenance is suggested.

Cleaning Cooking Grids

We suggest you wash your cooking grids in a mild soap and warm water solution. You can use a wash cloth or soft brush to clean your cooking grids.

Cleaning Flame Tamers

Periodically you should wash the flame tamers in a soap and warm water solution. Use a soft brush to remove stubborn burnt-on cooking residue. The flame tamers should be dry before you reinstall them.

Cleaning Grease Tray

The grease tray should be emptied and wiped down periodically and washed in a mild detergent and warm water solution. A small amount of sand or cat litter may be placed in bottom of grease tray to absorb the grease. Check the grease tray frequently, don't allow excess grease to accumulate and overflow out of the grease tray.

Annual Cleaning of Grill Interior

Burning-off the grill after every use will keep it ready for your next grill. However, once a year you should give the entire grill a thorough cleaning to keep it in top operating condition. Follow these steps.

1. Turn all burner valves to full OFF position.
2. Turn LP gas tank valve to full OFF position.
3. Detach LP gas hose and regulator assembly from your gas grill. Inspect for any damage and replace as necessary with manufacturer replacement part number found on parts list.
4. Remove and clean flame tamers, cooking grids and grill burners.
5. Cover each gas valve orifice with aluminum foil.
6. Brush inside and bottom of grill with a nylon brush, and wash with a mild soap and warm water solution. Rinse thoroughly and let dry.
7. Remove aluminum foil from orifices and check each orifices for obstruction.
8. Check each spark electrode, adjusting as needed. The space between the spark electric tip and spark receiver should be approximately 3/16".
9. Replace burners and adjust the gas collector box. The edge of collector box should be overlapping the burner port.
10. Replace flame tamers and cooking grids.
11. Reconnect gas source and observe burner flame for correct operation.

Cleaning Exterior Stainless Steel Surfaces

- Weathering and extreme heat can cause exterior stainless steel surfaces to turn tan in color. Machine oils used in manufacturing process of stainless steel can also cause this tanning color. Use a stainless steel cleaner to polish stainless steel surfaces of your grill. Never use abrasive cleaners or scrubbers because they will scratch and damage your grill.
- Keep outdoor cooking gas appliance area clear and free from combustible materials, gasoline and other flammable vapours and liquids.

Cleaning Burner Tubes and Burner Ports

- To reduce the chance of "FLASH-BACK" the procedure below should be followed at least once a month in late summer or early fall when spiders are most active or when your grill has not been used for a period of time.

Cleaning Burner Tubes and Burner Ports

To reduce the chance of "FLASH-BACK" the procedure below should be followed at least once a month in late summer or early fall when spiders are most active or when your grill has not been used for a period of time.

1. Turn all burner valves and gas tank valve to off position.
2. Detach the LP gas regulator assembly from your gas grill.
3. Remove cooking grids, flame tamers, and grease tray from the grill.
4. Remove the screws from the underside of each burner and lift the burners up and away from the gas valve orifice. Remove the rotating air control cap.
5. Using a bent stiff wire in the shape of a hook, air hose or a bottle brush, run it through the burner tube and inside several times to remove any debris.

--Keep the outdoor cooking gas appliance area clear and free from combustible material gasoline and other flammable using the grill.

--Do not obstruct the flow of combustion and ventilation air, check for this each time prior too sing the grill.

--keep the ventilation openings of the cylinder enclose are free and clear from debris, check for this each time prior to using the grill.

Cleaning and Maintenance

Regardless of which burner cleaning procedure you use, we recommend you also complete the following steps to help prolong burner life.

1. Use a fiber pad or nylon brush to clean the entire outer surface of each burner until free of food residue and dirt.
2. Clean any clogged ports with a stiff wire, such as an open paper clip.
3. Inspect each burner for damage (cracks or holes) and if such damage is found, order and install a new burner. After installation check to ensure that gas valve orifices are correctly placed inside the ends of the burner tubes. Also check the position of your spark electrode.



WARNING

The location of the burner tube with respect to the orifice is vital for safe operation. Check to ensure the orifice is inside the burner tube before using the gas grill. If the burner tube does not fit over the valve orifice, lighting the burner may cause explosion and/or fire.

HOW TO REPLACE MAIN BURNER

Step 1. Locate the burner onto the orifice.

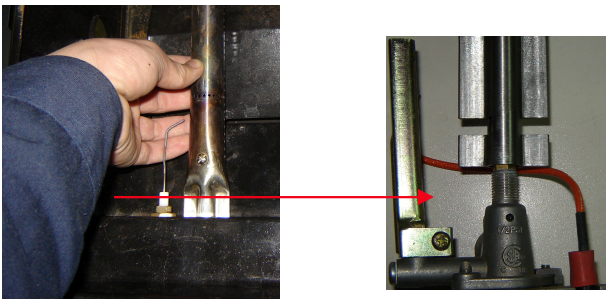

Step 2. Secure the main burner on the back wall of fire box with 2 screws.

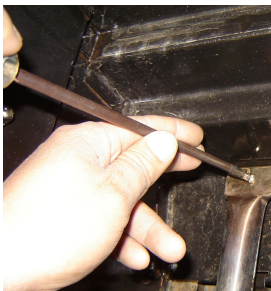

TROUBLE SHOOTING

SPIDER AND INSECT WARNING!!!

Spiders and insects can nest in the burners of this or any other grill, and cause the gas to flow from the front of the burner. This is a very dangerous condition which can cause a fire to occur behind the valve panel, thereby damaging the grill and making it unsafe to operate.

WHEN TO LOOK FOR SPIDERS

- 1. The smell of gas in conjunction with the burner flames appearing yellow.
- 2. The grill does not reach temperature.
- 3. The grill heats unevenly.
- 4. The burners make popping noises.

BEFORE CALLING FOR SERVICE

If the grill does not function properly, use the following check list before contacting your dealer for service. You may save the cost of a service call.

You should inspect the burners at least once a year or immediately after any of the following conditions occur:

CHECK LIST

PROBLEMS

Grill won't light when the control knob is rotated.

WHAT TO DO

- Check to see if LP tank is empty.
- Clean wire(s) and /or electrode by rubbing with alcohol and clean swab.
- Wipe with dry cloth.
- Make sure the wire is connected to electrode assembly.
- Do other burners on the unit operate?
- Check to see if other burners operate. If so, check the gas orifice on the malfunctioning burner for an obstruction.

Burner flame is yellow or orange, in conjunction with the odour of gas

Call our customer service hotline 1-800-469-4663

Low heat with knob in "HI" position

- Is the fuel hose bent or kinked?
- Is the grill in a dusty area?
- Is there adequate gas supply available?
- If it is only one burner that appears low, does the orifice or burner need cleaning?
- Is the gas supply, or gas pressure low?
- Is the grill being preheated for 15 minutes?

Getting Started with Your Grill

Cooking Instructions



WARNING

Do not leave the grill unattended.

Your grill will get very hot. Never lean over the cooking area while using your grill. Do not touch cooking surfaces, grill housing, grill Lid or any other grill parts while the grill is in operation, or until the grill has cooled down after use. Failure to comply with these instructions may result in serious bodily injury.

Burn-off

Before cooking on your gas grill for the first time, you will want to “burn off” the grill to eliminate any odour or foreign matter. Just ignite the burners, lower the Lid, and operate grill on the HIGH setting for 3 to 5 minutes.

Cooking Temperatures

High setting: Only use this setting for fast warm-up, searing steaks or chops and for burning food residue off the grill after cooking is complete. **Never** use the HIGH setting for extended cooking.

Medium to Low Settings: Most recipes specify medium to low settings, including all smoking, rotisserie cooking and for cooking lean cuts such as fish.

NOTE: Temperature settings will vary with the temperature and the amount of wind outside your home.

Direct Cooking

The direct cooking method can be used with the supplied cooking grids and food placed directly over the lit grill Burners. **Direct cooking requires the grill lid to be up.** The method is ideal for searing and whenever you want meat, poultry or fish to have an open-flame barbecued taste. Deep frying and smoking are also best cooked in this manner because they require direct heat.

Indirect Cooking

To cook **indirectly**, the food should be placed on the left or right side of your grill with the burner lit on the opposite side. **indirect cooking must be done with the Lid down.**

Flare-ups

The fats and juices dripping from grilled food can cause flare-ups. Since flare-ups impart a favorably, distinctive taste and color to food cooked over an open flame, they should be accepted up to a point. Nevertheless, uncontrolled flaring can result in a ruined meal.



WARNING

Do not line the bottom of the grill housing with aluminum foil, sand or any substance that will restrict the flow of grease into the grease tray. Failure to comply with these instructions could result in a fire or explosion which could cause serious bodily injury, death, or property damage.

CONGRATULATIONS

Your Kenmore gas grill is **now ready to grill.**

USING THE SIDE BURNER:

Inspect the gas supply hose prior to turning the gas “ON”. If there is evidence of cuts, wear or abrasion, it must be replaced prior to use. Do not use the side burner if the odour of gas is present. **WARNING: Always keep your face and body as far away from the burner as possible when lighting.**

LIGHTING INSTRUCTIONS

To light the side burner, remove any cooking utensils from the burner grate. Push and turn the control knob counterclockwise to the “HI” position. If the burner does not light, turn the control knob to “OFF”. If the smell of gas is detected and the igniter is not functioning, immediately turn the control knob “OFF”. Allow 5 minutes for any accumulated gas to dissipate and try again.



Approximate 1 1/2 " Flame Height

Rotisserie Kit Assembly and Use Instructions

Attaching Rotisserie Bracket to Grill

Tool required to assemble the product: Philips screwdriver(not provided)

Estimated time for assembly: 5 minutes

1. Using screwdriver to screw (2) 14 x 10mm, attach the bracket to the left side of the grill in the 2 pre-drilled holes. (See Fig. 1)
2. Slide rotisserie Motor over Bracket. (See Fig. 2)
Note: Motor model may be different than as pictured.
3. Place the rotisserie prongs into the rotisserie rod with caution. Then place shaft collar into the right end of the rotisserie rod. (See Fig.3)
4. Place rotisserie rod into the motor, make sure rotisserie rod aligns with the motor correctly and shaft collar onto the right side panel of fire bowl. (See Fig.4)
5. Assembly instructions for the counterbalance and handle are shown below. (See Fig. 5)
6. Completed Assembly. (See Fig. 6)

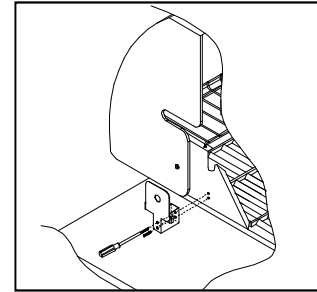

Fig. 1

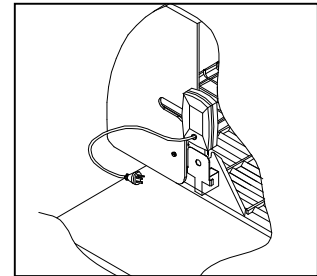

Fig.2

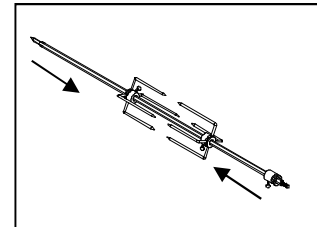

Fig.3

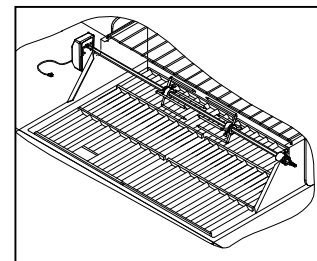

Fig.4

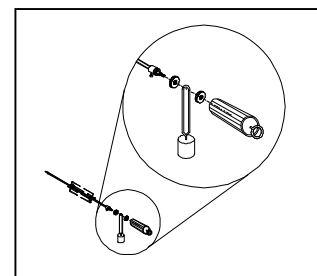

Fig. 5

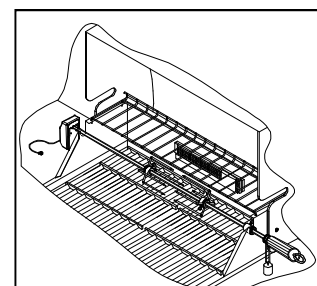

Fig.6

USING ROTISSERIE BURNER

Your grill is capable of performing back burner rotisserie cooking. Light the rear burner as described in the lighting instructions, see page 20. Once lit, the rotisserie burner will reach cooking temperatures in about 1 minute.

The motor slides onto the stainless steel motor mount. The rotisserie motor must be electrically grounded in accordance with local codes or, in the absence of local codes, with the National Electrical Code, ANSI/NFPA 70-1990.

The skewer for the rotisserie is assembled into the motor assembly by placing the pointed end into the motor, and then sliding the grooved bushing into the slot at the opposite side of the grill. The thumbscrew for the grooved bushing should be inside the grill body. To load the skewer, begin with the bushing screwed on the skewer rod at the opposite end from the point. Then slide the counter balance apparatus and tighten on the skewer rod approximately 2~4"(5-10cm) from the bushing. Slide the first meat fork onto the skewer rod prongs toward the food. Center the product to be cooked on the skewer then push the meat forks firmly together. Tighten the wing nuts as tight as possible.

It may also be necessary to wrap the food with butchers string (never use nylon or plastic string) to secure any loose portions. Once the food is secure insert the skewer into the motor. It is normal for the skewer to flex when larger cuts of meat are being cooked. It may also be necessary to remove the grill rods for larger cuts of meat. If the meat scrapes on the grill rods during any part of the rotation, then the grill rods must be removed. Adjust the counter balance weight to balance the heavier side of the meat and avoid lopsided rotation of the rotisserie motor. After your first use of the rotisserie burner it is likely that the stainless steel adjacent to the burner will darken to a dark blue color. This is a normal property of the non-rusting, type 304 stainless steel used on the grill.



WARNING

The rotisserie motor is quipped with a plug and should be plugged directly into a properly grounded receptacle. Do not cut or remove the grounding prong from this plug. Keep the rotisserie motor cord away from the heated surfaces of the grill. When not in use, remove and store the motor in a dry location.

GRILL COOKING CHART

FOOD	WEIGHT OR THICKNESS	FLAME SIZE	APPROXIMATE TIME	SPECIAL INSTRUCTIONS AND TIPS
VEGETABLES				
Fresh				Slice. Dot with butter or margarine. Wrap in heavy-duty foil. Grill, turning occasionally.
Beets		Medium	12 to 20 minutes	
Carrots				
Turnips				Grill, turning once. Brush occasionally with melted butter or margarine.
Onion	1/2 inch slices	Medium	8 to 20 minutes	
Potatoes				Wrap individually in heavy-duty foil. Grill, rotating occasionally.
Sweet	Whole	Medium	40 to 60 minutes	
White	6 To 8 ounces	High	45 to 60 minutes	
Frozen				Dot with butter or margarine. Wrap in heavy-duty foil. Grill. Turning occasionally.
Asparagus		Medium	15 to 30 minutes	
Broccoli				
Brussels				
Sprouts				
Green beans				
Peas				
French fries		Medium	15 to 30 minutes	Place in aluminum foil pan. Grill, stirring occasionally.
MEATS				
Beef				
Hamburgers	1/2 to 3/4 inch	Medium	10 to 18 minutes	Grill, turning once when juices rise to the surface. Do not leave hamburgers unattended since a flare-up could occur quickly.
		High	8 to 15 minutes	
Steaks				
Rib eye,				

GRILL COOKING CHART

FOOD	WEIGHT OR	FLAME SIZE	APPROXIMATE	SPECIAL INSTRUCTIONS
	THICKNESS		TIME	AND TIPS
Tenderloin, Porterhouse, T-Bone, Sirloin				Remove excess fat from edge. Slash remaining fat at 2-inch intervals.
Rare	1 inch	High	8 to 14 minutes	Grill, turning once.
	1-1/2 inch	High	11 to 18 minutes	
Medium	1 inch	Medium to	12 to 22 minutes	
	1-1/2 inch	High	16 to 27 minutes	
Well-done	1 inch	Medium	18 to 30 minutes	
	1-1/2 inches	Medium	16 to 35 minutes	
Lamb Chops & Steaks				Remove excess fat from edge. Slash remaining fat at 2-inch intervals.
Rare	1 inch	High	10 to 15 minutes	Grill, turning once.
	1-1/2 inch	High	14 to 18 minutes	
Medium	1 inch	Medium to	13 to 20 minutes	
	1-1/2 inch	High	18 to 25 minutes	
Well-done	1 inch	Medium	17 to 30 minutes	
pork				remaining fat at 2-inch intervals.
Chops	1 inch	Medium	20 to 30 minutes	Grill, turning once. Cook well done.
Well-done	1-1/2 inches	Medium	30 to 40 minutes	
Ribs		Medium	30 to 40 minutes	Grill, turning occasionally. During last few minutes brush with barbecue sauce, turn several times.
Pork Ham steaks				
(precooked)	1/2 inch slices	High	4 to 8 minutes	Remove excess fat from edge. Grill, turning once.
Hot dogs		Medium	5 to 10 minutes	Slit skin. Grill, turning once.
POULTRY				
Broiler/fryer	2 to 3 pounds	Low or	1 to 1-1/2 hours	brushing frequently marinade.
Halved or done		Medium	40 to 60 minutes	
Breasts well-done		Medium	30 to 45 minutes	

GRILL COOKING CHART

FOOD	WEIGHT OR THICKNESS	FLAME SIZE	APPROXIMATE TIME	SPECIAL INSTRUCTIONS AND TIPS
FISH AND SEAFOOD				
Steaks				Grill, turning once. Brush with melted butter, margarine or oil To keep moist.
Halibut	3/4 to 1 inch	Medium to	8 to 15 minutes	
Salmon		High		
Swordfish				
Whole				
Catfish 4 to 8 ounces	4 to 8 ounces	Medium to	12 to 20 minutes	Grill turning once. Brush with Melted Butter, margarine or oil.
Rainbow trout		High		

GRILL RECIPE SUGGESTIONS

BBQ SALMON

2 large salmon steaks
 2 tbs. Oil
 Salt & pepper
 2 oz. thin bacon slices
 2 tbs. Butter
 1 tbs. Lemon juice
 Spring of parsley
 Lemon wedges

Preheat the BBQ.

Brush the steaks with oil and season with salt and pepper. Place on BBQ grill and cook for 10 minutes, turning steaks over halfway cooking time.

Meanwhile fry the bacon in a pan on the side burner. Drain on paper towels. Melt the butter in a small saucepan taking care not to discolour it. Arrange the fish and bacon on serving plates. Pour the butter over and sprinkle with lemon juice. Garnish with parsley springs and lemon wedges. Serve with boiled potatoes tossed in butter and sprinkled with chopped parsley and a crisp lettuce salad.

Note: Substitute catfish, halibut or cod for salmon.

BAKED CHILI CORN

6 medium ears corn, husked
 3 tbs. Butter or margarine, melted
 Dash ground cumin
 Dash ground coriander

About ½ hour before cooking, turn the butter on for grill. Place each corn on a heavy-duty foil. In a bowl, combine remaining ingredients. Mix well. Brush 1-1/2 tsp. Butter mixture over each ear. Close foil and fold up ends to seal. Place on grill. Cook, turning packets occasionally 10 to 12 minutes or until cooked through.

PORK CHOPS

4 Pork chops
 Marinade
 1 large onion
 2 tbs. lemon juice or vinegar
 2 tbs. oil
 ½ tsp. powdered mustard
 2 tsp. Worcestershire sauce
 ½ tsp. freshly ground black pepper
 1 tsp. sugar
 ½ tsp. paprika
 1 clove garlic
 Peel, grate onion, and add rest of the ingredients except the pork chops. Mix well. Pour over chops and marinate one hour in a cool place. Turn the BBQ grill on full. Heat 10 minutes. BBQ the chops brushing with the marinade occasionally. Serve with mixed salad, dressed with vinaigrette flavored with fresh dill.
 3 tbs. chopped parsley
 1 tbs. vegetable oil
 1 tbs. Worcestershire sauce
 ½ tsp. prepared horseradish
 1 cove garlic, minced
 1 20 oz. Can pineapple chunks in juice, drained

Half hour before cooking, turn the burner to the grill on full. Drain seafood reserving marinade. On each of twelve 10" skewers, thread 2 shrimps and 2 scallops, alternating with pineapple chunks. Place skewers on grill. Cook 7-10 minutes, often basting and turning.

BARBECUED LONDON BROIL

4 to 6 servings
 ¾ c. Italian dressing
 1 tsp. Worcestershire sauce
 1 tsp. dry mustard
 ¼ tsp. thyme, crushed
 1 medium onion, sliced
 1 pound flank steak, scored
 2 tbs. butter, melted

Combine first 4 ingredients, add onion and marinade flank steak with it. Refrigerate at least 4 hours or overnight. Remove steak and grill on your preheated BBQ grill. Grill 5 to 7 minutes on each side basting frequently with the marinade. In the meantime sauté onions from the marinade in butter in a skillet on your side burner for 3 minutes. To serve, slice steak diagonally into thin slices, sprinkle onions over top. Garnish with vegetable kabobs.

BARBECUED POTATOES AND CHEESE

1-1/2 cups shredded cheddar cheese
 1 can (10-3/4 oz.) condensed cream of mushroom soup
 1/3 cup milk
 2 tbs. barbecue sauce
 ¼ tsp. oregano
 ¼ tsp. salt
 1/8 tsp. pepper
 4 cups thinly sliced potatoes (4 medium-sized potatoes)

GRILL RECIPE SUGGESTIONS

Preheat grill. Combine cheese, condensed soup, milk, BBQ sauce, oregano, salt and pepper in a large mixing bowl. Stir in potatoes until well coated. Turn into well buttered 1-1/2 quart rectangular baking dish. Cover dish with aluminum foil. Bake covered 25 minutes on medium with the lid of your BBQ grill closed. Remove foil and continue baking 15 minutes longer or until potatoes are tender. Let stand 5 minutes before serving.

VEGETABLE KABOBS

3 medium-sized zucchini
12 cherry tomatoes
12 fresh mushrooms
Grated Parmesan cheese

Parboil whole zucchini 5 minutes on your side burner or until just tender. Drain and cut into 1/2 inch slices. Thread zucchini, tomatoes and mushrooms alternately on each of six skewers. Brush with marinade made of Italian dressing, Worcestershire sauce, mustard and thyme. Grill 5 to 7 minutes turning and basting occasionally. Sprinkle liberally with Parmesan cheese.

FAJITAS

1-1/2 lb. flank steak or boned chicken breasts
2 tbs. oil
1/2 cup lime juice
1/2 tsp. salt
1/2 tsp. celery salt
1/4 tsp. garlic powder
1/2 tsp. pepper
1/4 tsp. oregano
1/4 tsp. cumin
Flour tortillas lemon

Pound flank steak to 1/4 inch thickness or flatten chicken breasts. Mix oil, lime juice and seasonings in a zip lock bag. Add meat and shake bag to coat the meat. Refrigerate overnight or at least 6 to 8 hours. Wrap tortillas in foil. Remove meat from marinade. Cook on a pre-heated gas grill for 5 to 8 minutes on each side. While meat is cooking, heat tortillas on grill. Slice meat across grain in thin slices. Place on hot platter. Squeeze lemon juice over. Wrap meat and any of the following toppings in tortillas: chopped tomatoes, guacamole, sour cream, taco sauce.

BEEF AND LAMB KABOBS

Serve 4

1/2 lb. boneless sirloin or beef cut into 1" cubes
1/2 lb. boneless loin of lamb cut into 1" cubes
2/3 c. water, divided
1/4 c. chopped onion
2 tbs. soy sauce
1/4 c. vegetable oil, divided
1 tbs. dark brown sugar
1 tbs. fresh lemon juice
2 cloves garlic, minced
1/4 tsp. ground cumin
1/4 tsp. ground coriander
1/4 tsp. ground turmeric
1/8 tsp. ground red pepper
1/8 tsp. ground ginger
1 red pepper cut into chunks
1 large banana, cut into chunks
8 small mushrooms
1/3 c. smooth peanut butter

In blender, process 1/3 c. water, onion, soy sauce, 2 tsp. oil and the next 8 ingredients until smooth. Pour over meat cubes and marinate about 4 hours, turning occasionally. Drain and reserve marinade. On four 12" skewers alternately thread meat, pepper, banana and mushrooms. Preheat grill. Brush the kabobs with oil. Grill 7-8 minutes each side.

Bring marinade to boil on the side burner in a saucepan. Add remaining 1/3 c. water and peanut butter. Stir to blend. Heat through. If sauce gets too thick, add 1 tbs. water. Serve sauce with kabobs.

EGGPLANT CAVIAR

1 large eggplant
2 tbs. olive oil
2 tbs. wine vinegar
2 tbs. finely chopped onion
1/2 clove garlic, minced
1 medium tomato, chopped salt and pepper

Roast eggplant on gas grill over medium flame, turning occasionally until thoroughly cooked. This may take 30 minutes. Remove from grill and cool for handling. Strip off the skin and chop eggplant finely. Add all the seasonings. Chill thoroughly and serve on toast.

GRILL RECIPE SUGGESTIONS

CHICKEN TANDOORI STYLE

8 large chicken thighs or drumsticks

1 c. plain nonfat yogurt

½ c. lemon juice

2 tsp. salt

½ tsp. cayenne

½ tsp. black pepper

½ tsp. crushed garlic

½ tsp. grated ginger

1 tbs. corn oil

Combine all the ingredients in a large mixing bowl and marinate the chicken for 8 hours in the refrigerator. Drain the chicken and spread on the spit running the rod on the fleshier side of the bone.

Rotis using the rotisserie burner. Cook on medium high heat for 40 minutes basting occasionally with the remainder of the marinade mixture. Serve with sliced onions and lemon wedges.

SPARE RIBS

Marinade:

1 c. soy sauce

½ c. honey

½ c. vinegar

½ c. dry sherry

2 tsp. chopped garlic

2 tsp. sugar

1 c. water

1 chicken bouillon cube

1 can beer for basting sauce

Marinate ribs for 3 hours. Use marinade for basting by adding beer to it. Place pan under the ribs and baste frequently. To cook ribs select lean, meaty ribs and accordion pleat them with your spit. Slide four prong meat hook down the length of spit and tighten. At the beginning of

the rack and to its center, penetrate the second rib with the pointed end of the spit and push it between the meat. Skip a couple and continue the process until the entire rack is accordion pleated. Fasten the second meat hook into the rack. Turn your rotisserie burner on high. Rotis for 50 minutes or until done.

PORK ROAST

Apple cider vinegar basting sauce:

1 c. apple cider vinegar

6 oz. water

½ stick butter

Salt, pepper, parsley and garlic seasoning

2 oz. lemon juice

10 lbs. pork roast

Time: 1-1/2 hours to 2 hours

Bring pork to room temperature before placing it on the spit rod. Place on the rod and test for balance. Light rotis burner. Turn control knob to high. Use the above basting sauce for rotissing.

TURKEY

12 lb. turkey

Beer basting sauce:

1 can beer

12 oz. water

1 stick butter

1 tsp. salt

1 tsp. pepper

½ tsp. garlic flakes

1 tsp. parsley

Thaw the bird completely. Wash inside out. Securely tie the legs and wings. Light rotisserie burner. Turn to high. Combine all the ingredients for basting sauce in a shallow pan. Place it under the turkey 15 to 20 minutes. Cook for approximately 3 hours. The basting sauce combined with turkey drippings makes a delicious gravy.

Get it fixed, at your home or ours!

Just Call:

1-800-4-MY-HOME[®]

(1-800-469-4663)

24 hours a day, 7 days a week

For the repair of major brand appliances **in your own home...**
no matter who made it, no matter who sold it!

For your nearest **Sears Parts and Service** location,
to bring in products like vacuums, lawn equipment and electronics.

For **Sears Parts & Service**, to order the replacement parts,
accessories and owner's manuals that you need to do-it-yourself.

sears.ca

To purchase or inquire about a Sears Maintenance Agreement, call:

1-800-361-6665

9 a.m. – 8 p.m. EST, Mon. – Fri., 4 p.m. Sat.

Pour service en français:

1-800-LE-FOYER^{MC}

(1-800-533-6937)

sears.ca

